

# bj-gear



## Actuators with belt drive

### Manual

Customisation is our standard

# Mounting and relubrication guide

## Stainless ball screw actuator

**Series:** AK 00 4xx  
AK 00 7xx  
AK 00 9xx

### Mounting:

- It is important that the actuator is well aligned and there is no tension between the parts. It is recommended to mount it without tightening the fixations. Run the actuator manually from one end to the other, to see if it runs freely and then tighten the fixations.
- Do not subject the actuator to radial loads.
- Design of the actuator does not allow it to run against mechanical end stops, not even its own end limits. To find the end limits, line up the end of the inner tube with the black bushing of the outer tube until  $X=0$  (see fig. 1). In this position there is still 2 mm to the end limit. To find the opposite end limit, position the actuator until  $X$  equals the nominal stroke. In this position there is still 5 mm until the end limit.
- To be able to relubricate without dismantling actuator, it is important that the mark on the inner tube is line up with the regrease hole of the outer tube (fig. 1) when mounted.
- Remove the protection screw of the outer tube, and fit the lubrication nipple, which was delivered along with the actuator. Before removing the protection screw, be sure that the surface around it is clean.
- When the ball screw has been lubricated, remove the grease nipple and refit the protection screw.
- If there is no brake on the motor, it can not be expected that the actuator keep its relative position.

### Relubrication:

- When the actuator is delivered it is prelubricated. To be able to function correctly and obtain its lifetime, it is very important that the actuator is relubricated at certain intervals. It is the responsibility to the owner to ensure that it does not run dry. Relubrication interval depends on several factors, such as temperature, load, speed and cleanness. In the table are guidelines to relubrication interval for spindles with a certain load. Values are given under the following conditions: Speed: min. 100 min<sup>-1</sup> and max temperature on ball screw nut: 60° C.
- Use ordinary ball bearing grease NLGI class 2 for relubrication. Guidelines for the amount of grease to use are given in the table.
- To relubricate the actuator run the inner tube until the measure  $X$  equals the stroke. If not done already, line up the mark of the inner tube with the lubrication hole of the outer tube as described above. Run the inner tube a little forward or backward until the holes are completely aligned.

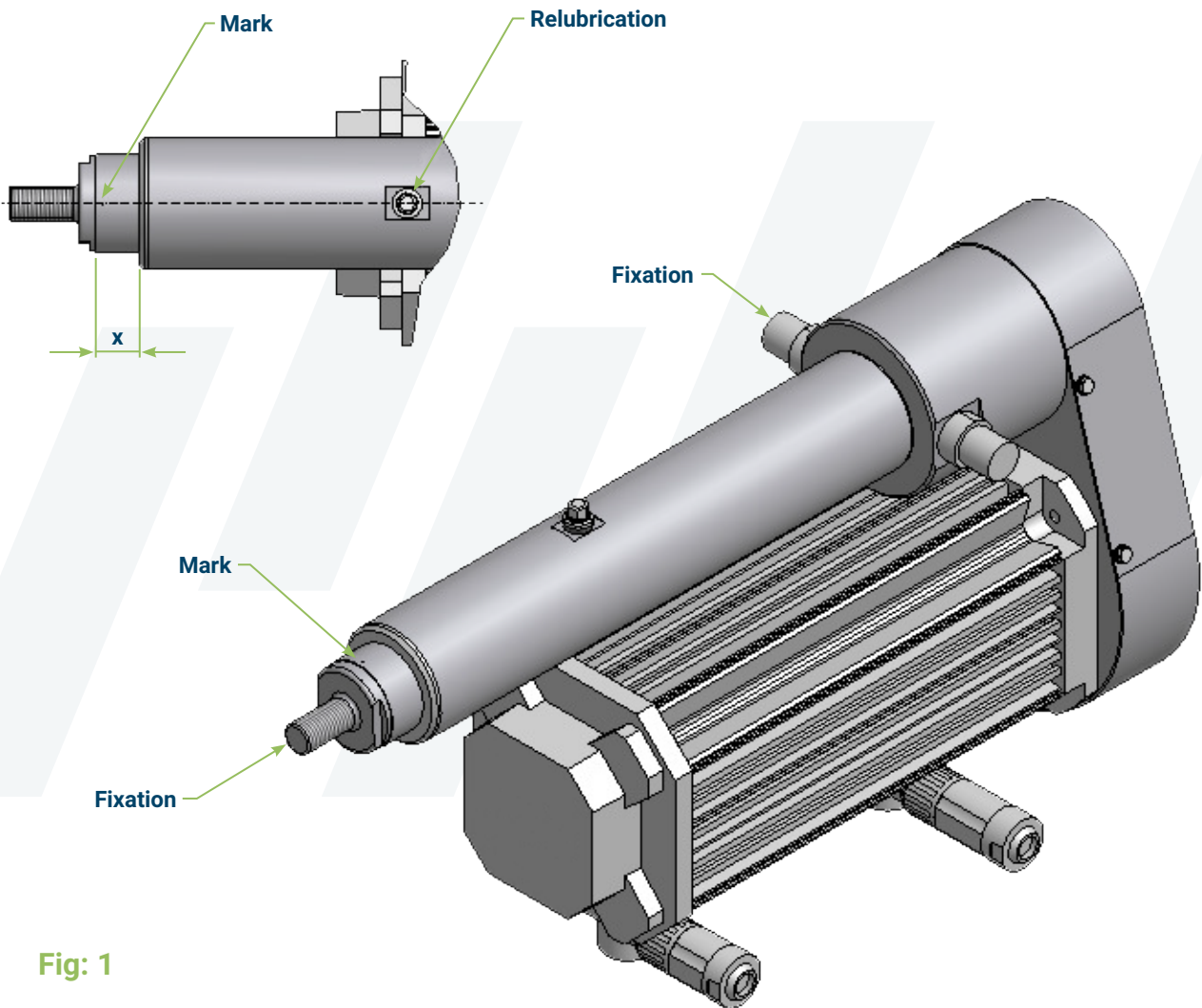

Fig: 1

Guidelines to relubrication interval and grease amount					
Pitch [mm]	16 x 6	16 x 16	25 x 5	25 x 10	25 x 25
Relubrication interval [km]	250	800	250	500	1250
Load [N]	2460	1260	3180	3140	2640
Grease amount [g]	0,6	0,9	1,5	2	3



bj-gear

**bj-gear**

Niels Bohrs Vej 47  
DK-8660 Skanderborg, Denmark  
VAT No. DK 10166470

Phone +45 87 40 80 80  
Email [bj@bj-gear.com](mailto:bj@bj-gear.com)  
Website [www.bj-gear.com](http://www.bj-gear.com)

Copyright © 2020 BJ-Gear A/S. All product rights reserved.  
All data, illustrations, photos, drawings and statements are for  
general information only and subject to change without notice and  
should not be considered as a warranty or legal obligation of any kind.

AB | 06 | 2021 | UK